



**Model 2500A**

The Model 2500A Bias Reversing Relay provides an outlet pressure that decreases in direct proportion to increases in input signal.

## Features

- Control sensitivity of 1" water column allows use in precision applications
- Large Supply and Exhaust Valves provide high forward and exhaust flows
- Soft Supply and Exhaust Valve seats minimize air consumption
- A balanced Supply Valve minimizes the effect of supply pressure variation
- An Aspirator Tube compensates downstream pressure droop under flow conditions
- A separate Control Chamber isolates the diaphragm from the main flow to eliminate hunting and buzzing
- Unit construction lets you service the Model 2500A without removing it from the line

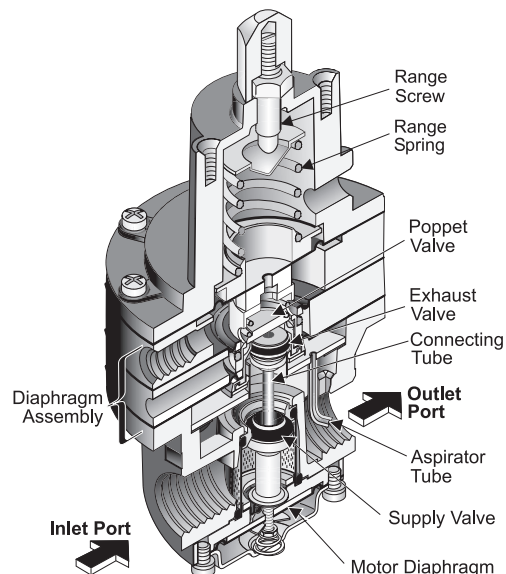

## Operating Principles

When you adjust the Range Screw to a specific setpoint, the Range Spring exerts a force against the top of the Diaphragm Assembly. The increasing input signal that acts on the Diaphragm Assembly opposes the Range Spring force and closes the Supply Valve to decrease output pressure. ( $P_o = K - P_s$ ); where  $P_o$  is output pressure,  $K$  is the spring constant, set by the screw, and  $P_s$  is signal pressure. The output pressure flows through the Outlet Port and the Aspirator Tube to the Control Chamber to create an upward force on the bottom of the Control Diaphragm.

When the setpoint is reached, the net downward force of the Diaphragm Assembly balances with the upward force of the output pressure that acts on the bottom of the Control Diaphragm to close the Supply Valve.

When the output pressure increases above the setpoint, the Diaphragm Assembly moves upward to close the Supply Valve and open the Exhaust Valve. When the Poppet Valve is closed, pressure flows down the Control Tube to the bottom of the Motor Diaphragm. This pressure keeps the Supply Valve tightly closed while in the exhaust mode. The Poppet Valve opens and excess output pressure exhausts through the Vent in the side of the unit until it reaches the setpoint.

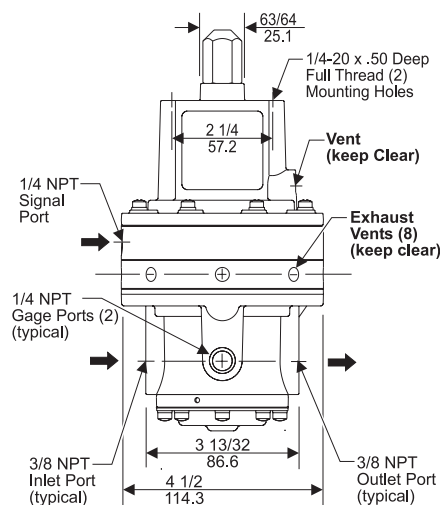
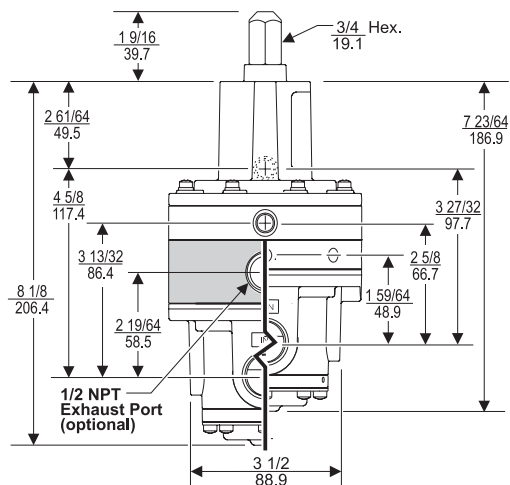

# Model 2500A Biasing Reversing Relay

## Technical Information

Flow Characteristics  
Fairchild Model 2564A

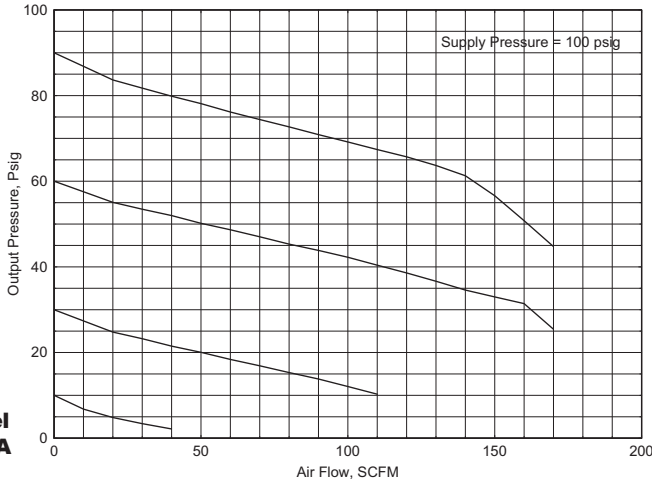

Model  
2500A

## Specifications

### Maximum Supply Pressure

250 psig, [17.0 BAR], (1700 kPa)

### Maximum Signal or Output Pressure

150 psig, [10 BAR], (1000 kPa)

### Flow Capacity

150 SCFM (255 m<sup>3</sup>/HR) @ 100 psig, [7.0 BAR], (700 kPa) supply, 20 psig, [1.5 BAR], (150 kPa) setpoint

### Exhaust Capacity (SCFM)

40 SCFM (68 m<sup>3</sup>/HR) where downstream pressure is 5 psig, [.35 BAR], (35 kPa) above 20 psig, [1.5 BAR], (150 kPa) setpoint

### Supply Pressure Effect

Less than 0.1 psig, [.007 BAR], (0.7 kPa) for 100 psig, [7.0 BAR], (700 kPa) change in supply pressure

### Sensitivity

1" (2.54 cm) Water Column

### Ambient Temperature

-40°F to +200°F, (-40°C to 93.3°C)

### Materials of Construction

Body and Housing ..... Aluminum  
Trim ..... Zinc Plated Steel, Brass  
Diaphragms ..... Nitrile on Dacron

## Catalog Information

### Catalog Number

2 5   A

### Pressure Range

psig	[BAR]	(kPa)	
0.5-10	[0.03-0.7]	(3-0.7) .....	2
0.5-30	[0.03-2]	(3-200).....	3
1-60	[0.1-4]	(10-400) .....	4
2-150	[0.15-10]	(15-1000) .....	6

### Pipe Size

3/8" NPT .....	3
1/2" NPT .....	4
3/4" NPT .....	6

### Options

Tapped Exhaust ..... E

## Installation

For installation instructions, refer to the *Fairchild Model 2500A Multi-Stage Relay Installation, Operation, and Maintenance Instructions*, IS-3002500A.

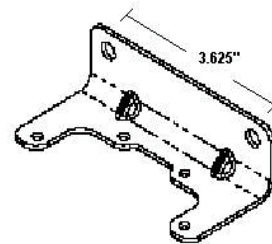

20555-1

### Model 2500A Mounting Bracket Kit P/N

20555-1 zinc plated (sold separately)